

GW MODEL C300

FLUID CONTROL VALVES

GENERAL DATA

The GW C300 high performance fluid control valve is an extremely versatile wafer type unit with a varied number of options and applications. The valve was developed in conjunction with major oil companies to perform in harsh offshore petrochemical environments. The GW C-300 range of valves has been widely used within the oil & gas industry for more than 20 years – serving as the key component in fire protection systems where reliable water control is called for.

It is capable of a wide flow range with comparatively low pressure losses and can provide accurate pressure control for many uses. The unit, with its accessories can be used for applications where upstream or downstream pressure sensing and control is required. In the non-pressure reducing versions the GW C-300 valve serves as an on-off valve with adjustable opening and closing speed.

The C300 is available in a range of sizes from 80mm (3" nominal) to 300mm (12" nominal) and in a range of materials (Ni. Al. Bronze, SuperDuplex Cr.25, Titanium Gr.2) for all environments.

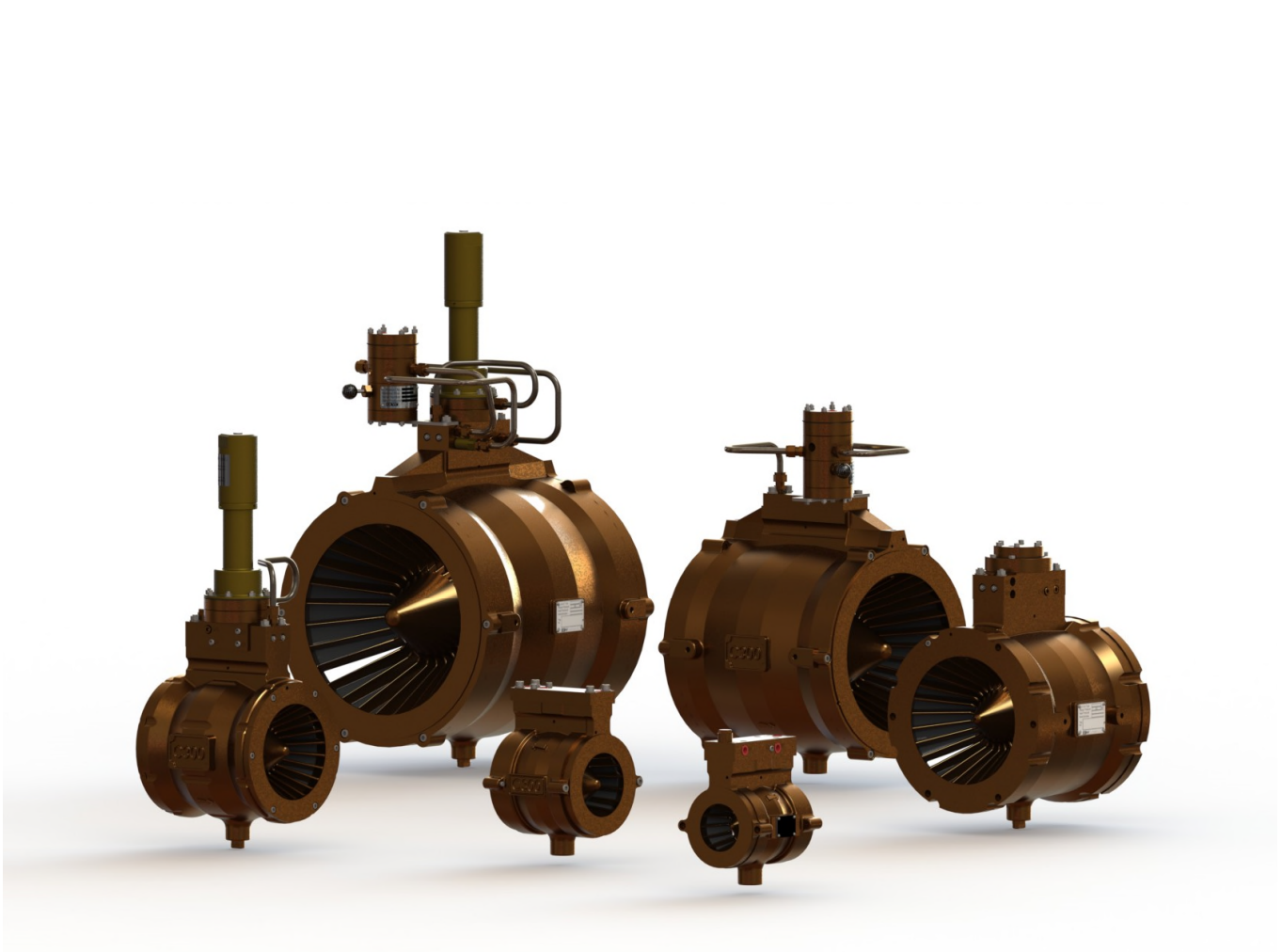

GW SPRINKLER A/S

Kastanievej 15, DK-5620 Glamsbjerg, Denmark
Tel: +45 64 72 20 55 Fax: +45 64 72 22 55
Email: sales.dep@gwsprinkler.com

Data Sheet:

Page: Page 1 of 8

DATA SHEET No: **DV050 1001 B**

Date: 16 May 2018

GW MODEL C300

FLUID CONTROL VALVES

GENERAL DATA

FEATURES:

- **Pressure reduction & Cavitation control.**
 - All pressure reducing valves cause cavitation under particular flow conditions. The C300 valve manages the cavitation due to its unique internal design. As the water flows through the valve the pressure reduction is carried out at multiple sites in the centre of the water flow.
 - The collapsing water vapour or cavitation sites are consequently smaller and in the centre of the water flow. The cavitation is therefore less prone to attach itself to the valve or pipework and cause damage. This allows the valve to operate over a wide pressure reduction range.
- **Wide operating range.**
 - Flow ranges from nearly zero up to 10 m/s are available from every valve without modification.
 - Compromise is not required between low flow control and fully open low pressure losses.
- **Reliability.**
 - Fit and forget. Fundamental principles used in the valve design ensure that reliability is built in.
 - Separating water from metallic moving parts with elastomeric diaphragms.
 - Failure of a diaphragm will not stop the valve working.
 - Valve functions in hard water, soft water and sea water.
- **Low head losses.**
 - When the C300 valves are in the wide open position they have extremely low pressure head losses. This allows the use of smaller valves therefore reducing pipe and valve costs in a given system.
- **Progressive opening.**
 - Within the C300 valve there are no sudden changes in profile, which allows the valve to open and close smoothly over its full operating range.
 - The C300 valve will not allow sudden pressure surges or instability to progress downstream. This prevents damage to fittings/pipework and ensures a stable operating system. The factory set opening and closing speeds can be adjusted on site to give optimum performance.
- **Flow Summary:**

| Min. Flow Rate (lpm) (x 0.06 for m3/hr) | Valve Sizes: | | | | | |
|---|--------------|-----|-----|-------|-------|-------|
| | 80 | 100 | 150 | 200 | 250 | 300 |
| Sprinkler | 100 | 100 | 100 | n/a | n/a | n/a |
| Deluge / PRV | 200 | 200 | 400 | 2.000 | 3.000 | 4.500 |

| Max. Flow Rate (lpm) (x 0.06 for m3/hr) | Valve Sizes: | | | | | |
|---|--------------|-------|--------|--------|--------|--------|
| | 80 | 100 | 150 | 200 | 250 | 300 |
| Sprinkler | 1.800 | 3.000 | 7.000 | n/a | n/a | n/a |
| Deluge / PRV | 3.000 | 5.000 | 11.200 | 20.000 | 30.000 | 45.000 |

GW SPRINKLER A/S
Kastanievej 15, DK-5620 Glamsbjerg, Denmark
Tel: +45 64 72 20 55 Fax: +45 64 72 22 55
Email: sales.dep@gwsprinkler.com

Data Sheet:

Page: Page 2 of 8

DATA SHEET No: DV050 1001 B

Date: 16 May 2018

Valve Option Details – Non Regulating Valves.

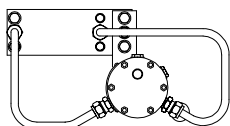

Non Regulating
with Actuator

DV050 1018

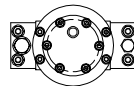

Non Regulating
with Internal
Actuator

DV050 1010

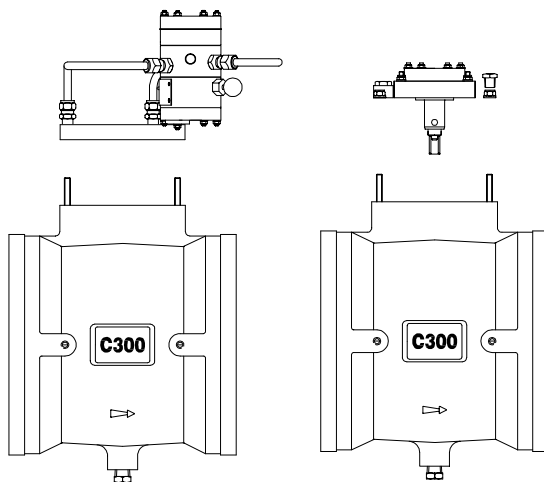

Non Regulating with External or Internal/Integral Actuator

The valve will open and close upon the application and removal of air pressure from the pilot valve. Opening and closing speeds are adjustable on site. Available with mechanical latch / manual reset option.

GW SPRINKLER A/S

Kastanievej 15, DK-5620 Glamsbjerg, Denmark

Tel: +45 64 72 20 55 Fax: +45 64 72 22 55

Email: sales.dep@gwsprinkler.com

Data Sheet:

Page:

Page **3** of **8**

DATA SHEET No: DV050 1001 B

Date:

16 May 2018

Valve Option Details – Non Regulating Valves.

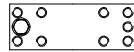

Non Regulating
 with Interface Plate
DV050 1005

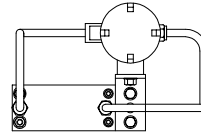

Non Regulating with
 Solenoid Actuator &
 Manual Over-ride
DV050 1009

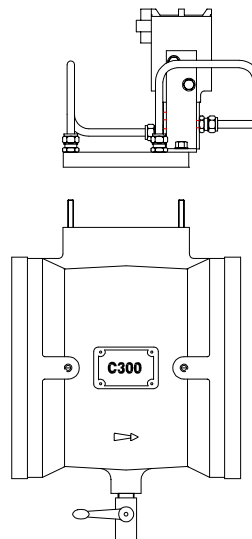
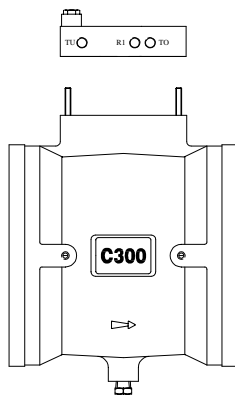

Non Regulating with Interface Plate (incl. strainer & restrictors)

The valve will interface with a control valve (not supplied). Opening and closing speeds are adjustable via integral restrictors.

Non Regulating with Solenoid Actuator and Manual Over-ride

This valve is similar to the “Non Regulating” valve DV050 1005 but fitted with a solenoid valve (actuator) and manual release ball valve.

It can be operated either electrically or manually.

GW SPRINKLER A/S

Kastanievej 15, DK-5620 Glamsbjerg, Denmark

Tel: +45 64 72 20 55 Fax: +45 64 72 22 55

Email: sales.dep@gwsprinkler.com

Data Sheet:

Page:

Page 4 of 8

DATA SHEET No: DV050 1001 B

Date:

16 May 2018

Valve Option Details – Regulating Valves.

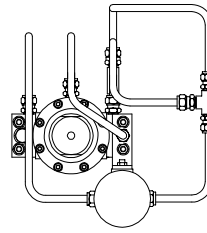
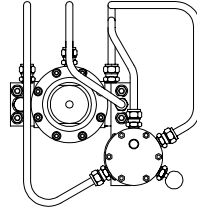
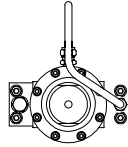

Regulating
DV050 1006

Regulating with
 Actuator
DV050 1007

Regulating with
 Solenoid Actuator &
 Manual Over-ride
DV050 1008

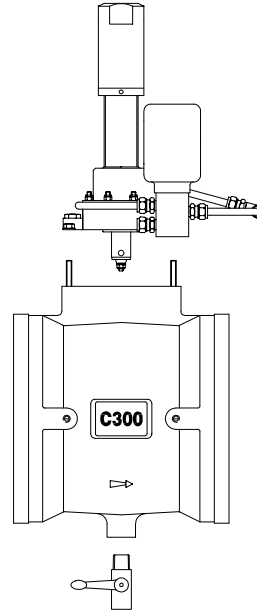
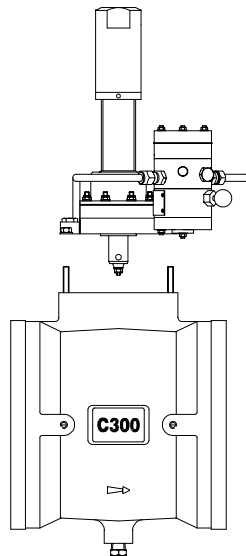
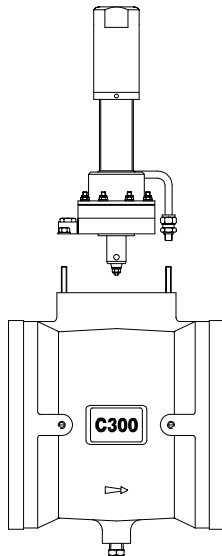

Regulating – Pressure Reducing.

This type of valve is fitted into a fire water main to open upon instruction and provide a regulated downstream pressure to a pre-set value, irrespective of the flow rate and upstream pressure conditions.

Regulating with Actuator.

This valve is similar to the “Regulating” valve above but fitted with a pneumatically operated actuator.

Regulating with Solenoid Actuator and Manual Over-ride

This valve is similar to the “Regulating” valve above but fitted with an electrically operated actuator (solenoid valve) and manual release ball valve.

It can be operated either electrically or manually.

GW SPRINKLER A/S

Kastanievej 15, DK-5620 Glamsbjerg, Denmark

Tel: +45 64 72 20 55 Fax: +45 64 72 22 55

Email: sales.dep@gwsprinkler.com

Data Sheet:

Page:

Page 5 of 8

DATA SHEET No: DV050 1001 B

Date:

16 May 2018

Valve Option Details – Pressure Control Valves.

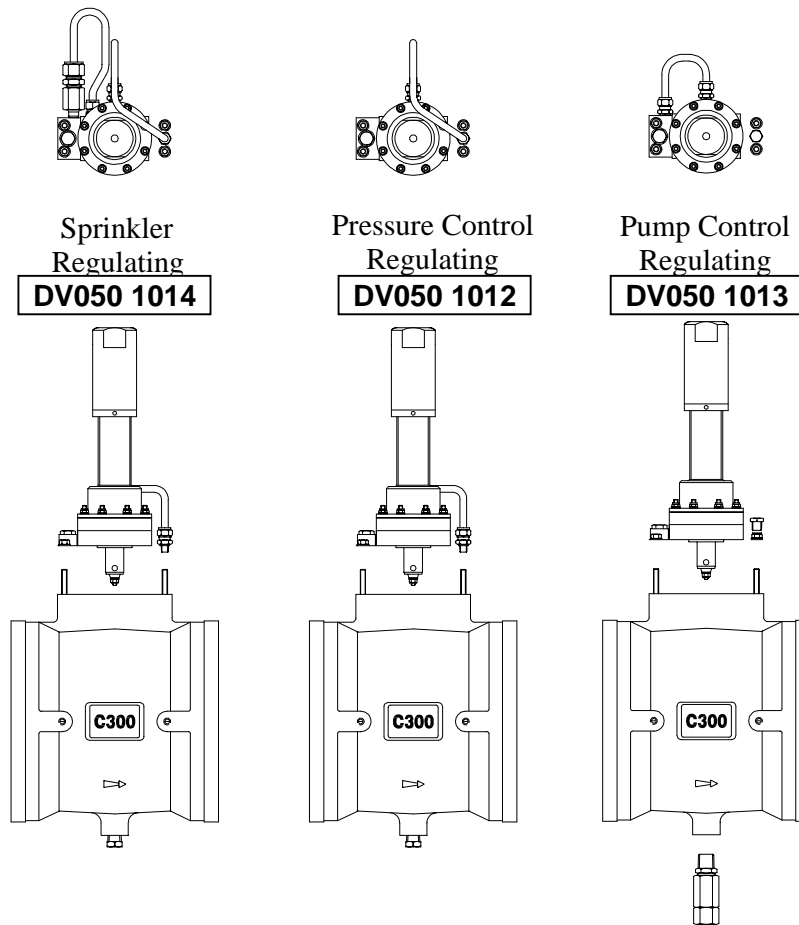

Sprinkler - Regulating

The valve is fitted in a fire water supply to provide a pressure regulated water supply to sprinkler heads and, upon operation, to provide an alarm (e.g. via a pressure switch fitted in TP5 port) . It operates using an elastomeric flow control sleeve.

Pressure Control - Regulating

This valve is fitted in a fire water supply to provide a pressure regulated water supply to flow demands where the downstream pipe work from the valve is required to be wet e.g. fire hydrants, and also to provide a maintained downstream pressure irrespective of upstream pressure or flow demand.

Pump Control - Regulating

The Pump Control Valve is interactive with the firewater ring main and is directly operated by the water flow/pressure from the fire pump.

The pump control valve maintains the required pressure and flow of water in a fire main by dumping excess water (pressure) to drain. The Pump Control Valve will continue to control the flow/pressure for as long as the fire pump is running. The Pump Control Valve is fitted with an Auto Bleed Valve to drain the sleeve cavity thus maintaining the valve fully open in the stand-by condition.

GW SPRINKLER A/S

Kastanievej 15, DK-5620 Glamsbjerg, Denmark
 Tel: +45 64 72 20 55 Fax: +45 64 72 22 55
 Email: sales.dep@gwsprinkler.com

Data Sheet:

Page: Page 6 of 8

DATA SHEET No: DV050 1001 B

Date: 16 May 2018

GW MODEL C300

FLUID CONTROL VALVES

GENERAL DATA

TECHNICAL SPECIFICATION & OPTIONS:

| | | |
|--------------------|-------------|----------------------------|
| Operation options: | Electrical: | Latch Open or Non Latching |
| | Pneumatic: | Latch Open or Non Latching |
| | Hydraulic: | Latch Open or Non Latching |
| | Manual: | |

| | | |
|-----------------|---------------------|--|
| Pressure Range: | Min. Water Supply: | 5 bar Regulating (3 bar non-regulating). |
| | Max. Water Supply: | 20 barg. |
| | Regulated Pressure: | 3 to 7 barg. (standard) |
| | | 7 to 12 barg. (optional) |

| | | |
|--------------------------------------|---------------------|--|
| Connections: (See diagram below). | Wafer Type Body: | To fit ANSI Class 150lb & 300lb RF flanges |
| | Trim Ports: | ¼" NPT |
| | Valve Jacket Drain: | ½" NPT |

| | | | | | |
|------------|----------------------|-----------------------|----------------|--------------------|--|
| Materials: | Valve type: | Ni. Aluminium Bronze | Titanium | Super Duplex Cr.25 | |
| | Valve body: | Ni. Aluminium Bronze | Titanium | Super Duplex Cr.25 | |
| | Wetted components: | Ni. Al. Bronze | Titanium | Super Duplex Cr.25 | |
| | Pipework: | Cu/Ni 90/10 | Titanium | Titanium | |
| | Flow control sleeve: | Natural Rubber | Natural Rubber | Natural Rubber | |
| Media: | | Freshwater / Seawater | Seawater | Seawater | |

Note: The correct material should be selected to correspond with media/environment used.

See individual valve data sheets for:

- Technical Specifications.
- Part Numbers.
- Piping and Instrumentation Diagrams.
- Dimensions.
- Weights.
- Maintenance instructions.

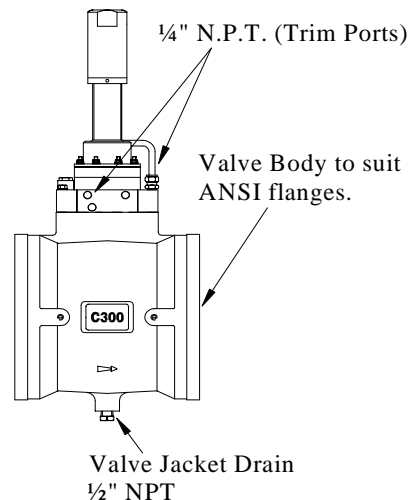

GW SPRINKLER A/S

Kastanievej 15, DK-5620 Glamsbjerg, Denmark
 Tel: +45 64 72 20 55 Fax: +45 64 72 22 55
 Email: sales.dep@gwsprinkler.com

Data Sheet:

Page: Page 7 of 8

DATA SHEET No: **DV050 1001 B**

Date: 16 May 2018

GW MODEL C300

FLUID CONTROL VALVES

GENERAL DATA

VALVE OPTION SUMMARY.

Complete Range of C300 Fluid Control Valves:

| Reference No. | Description of Valve | Valve Actuator | Areas of Application (onshore and offshore) | Standby Position |
|---------------|---|-----------------------|--|------------------|
| | Non Regulating | None supplied | An On/Off valve. e.g. water spray systems, standpipes or monitors. | ----- |
| DV050 1018 | Non Regulating with ext. Pneu. Actuator. | Manual/ Pneumatic | | Normally Closed. |
| DV050 1010 | Non Regulating with Internal Actuator. | Pneumatic | | Normally Closed. |
| DV050 1005 | Non Regulating with str.& restr. block | None supplied | | ----- |
| DV050 1009 | Non Regulating with Solenoid Actuator & Manual Over-ride | Manual/ Electric | | Normally Closed. |
| DV050 1006 | Deluge Regulating. | None supplied | Valve used where a regulated downstream pressure is required e.g. in a deluge system. | ----- |
| DV050 1007 | Deluge Regulating with Pneu. Actuator. | Pneumatic | | Normally Closed. |
| DV050 1008 | Deluge Regulating with Solenoid Actuator & Manual Over-ride | Manual/ Electric | | Normally Closed. |
| DV050 1014 | Sprinkler Regulating | No actuator required. | Valve used in a fire water main supplying sprinkler heads and providing an alarm signal. | Normally Open. |
| DV050 1012 | Pressure Control Regulating | No actuator required. | Valve used where a regulated downstream pressure is required in a water main supplying wet pipework e.g. hydrants. | Normally Open. |
| DV050 1013 | Pump Control Regulating | No actuator required. | Valve used where a regulated pressure is required in a fire water ring main e.g. oil platform ring mains. | Normally Open |

Additional Data Sheets Available

| | | |
|------------|------------------|--|
| DV050 1015 | Actuator | An auxiliary actuator that provides either pneumatic, hydraulic or manual operation of a C300 valve to open or close upon instruction. |
| DV070 1001 | General Spares | General Spare Parts Schedule |
| - | Auto Drain Valve | Technical Data |

Regulating Pressure Range:

The upstream pressure range is between 5 and 20 bar.

The valve pilot spring is factory pre-set at 4 bar as standard, but is site adjustable between 3 – 7 bar as standard, or with the option of a 7 – 12 bar range (special pilot spring must be fitted).

GW SPRINKLER A/S

Kastanievej 15, DK-5620 Glamsbjerg, Denmark
Tel: +45 64 72 20 55 Fax: +45 64 72 22 55
Email: sales.dep@gwsprinkler.com

Data Sheet:

Page: Page 8 of 8

DATA SHEET No: **DV050 1001 B**

Date: 16 May 2018