

GW C300

AUTOMATIC WATER CONTROL VALVE

PRESSURE REDUCING
WITH PNEUMATIC ACTUATOR



GW SPRINKLER A/S

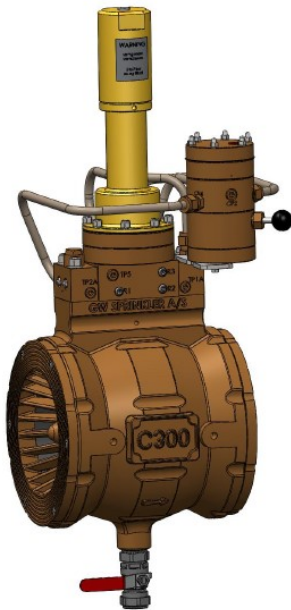

PART NUMBER			
	Ni Al Bronze	Super Duplex	Titanium
3"	CV64.515.24FM	CV64.515.26FM	CV64.515.27FM
4"	CV64.516.24FM	CV64.516.26FM	CV64.516.27FM
6"	CV64.517.24FM	CV64.517.26FM	CV64.517.27FM
8"	CV64.518.24FM	CV64.518.26FM	CV64.518.27FM
10"	CV64.519.24	CV64.519.26	CV64.519.27
12"	CV64.520.24	CV64.520.26	CV64.520.27



Note:
10" and 12" valves are not FM approved.

Function: This valve is typically fitted into a fire water main to open upon instruction, and provide a regulated downstream pressure to a pre-set value, irrespective of the flow rate and up-stream pressure conditions. Installation can be either horizontally or vertically. The GW C-300 deluge valve is "self-powered" – and utilizes the system upstream (inlet) pressure to hydraulically close, open and regulate. It is operated pneumatically via the actuator, to trip upon pilot line air pressure drop. The actuator is latched in the fail-safe open position, and must be manually reset locally. The actuator is also available without latch/manual reset for remote resetting of the deluge valve.

Operation: This elastomeric sleeve type valve is normally closed, and is maintained in the closed position by diverting upstream water directly to the flow control sleeve cavity. This is accomplished by the pneumatic actuator mounted on the deluge valve in the pressurized (air on) position. Upon instruction (air off) the actuator switches to open position and water is allowed to drain from within the sleeve cavity, thus releasing the hydraulic pressure that seals the sleeve against the seat. The deluge valve opens in a controlled way as upstream pressure lifts the sleeve off the seat and water starts flowing through the valve. The opening (and closing) speed is adjustable via restrictors controlling the in and out flow to the sleeve cavity, thus preventing water hammer and damage to downstream pipework and components. Pressure regulation is accomplished by the pilot control valve which will feed or drain water to/from the sleeve cavity, to open or close the flow orifice as required, when sensing the downstream pressure and comparing it to the pre-set pilot pressure.

The valve is maintained in the open position by the pneumatic actuator which remains in the "latched on" position once operated.

The GW C-300 deluge valve can be manually activated by opening the **manual release** valve (1/2" Ball Valve) fitted at the bottom of the valve body.

GW SPRINKLER A/S

Kastanievej 15, DK-5620 Glamsbjerg, Denmark
Tel.: +45 64 72 20 55 Fax.: +45 64 72 22 55
Email: sales.dep@gwsprinkler.com

Page: 1 of 5

DATA SHEET No: **DV050 1007 C**

Issue / Date: 02.07.2019

GW C300

AUTOMATIC WATER CONTROL VALVE

PRESSURE REDUCING WITH PNEUMATIC ACTUATOR



GW SPRINKLER A/S

Installation: Horizontally or vertically.
Fits between ANSI /ASME B16.5 Class 150 or 300 lbs. flanges

Design: The GW C-300 deluge valve is developed and designed for maximum reliability when installed and operated in the harshest onshore and offshore environments. To prevent any malfunctioning due to components seizing, sticking or corroding, the number of moving mechanical parts has been reduced to a minimum, and the few moving parts present are ALL 100% isolated (i.e. no water contact) from the flow media. The only moving components in contact with the flow media are the elastomeric parts. A strainer is fitted in the inlet of the valve center block to prevent any debris from entering the hydraulic pilot regulating system.

Pressure Reduction: The GW C-300 valve is designed to handle large pressure reductions, and minimize the effects of cavitation and noise. The multi finger construction of the water passageways through the valve, in combination with the conical shaped core, ensures that the pressure is reduced at multiple sites, which avoids large cavitation concentrations and resultant noise and valve damage. The exiting cone in the valve outlet ensures that the cavitation stays longer in the water flow stream thus reducing concentrated damage to valve internals and pipework walls.

Material: All materials used in the valve have been rigorously selected to ensure durability when installed and operated in the heavy duty applications the valve is designed for. All wetted parts are as standard in the material Nickel Aluminium Bronze and piping in CuNi 90/10.

Finish: Natural (metallic, non-painted surface).

Approval:



The GW C-300 Pressure Regulating valve is FM Approved to FM Class 1362: "Approval Standard for Pressure Reducing Valves", with below pilot limitations:

Pilot Limitations:

Regulated Pressure (set pressure)		Upstream Pressure min. / max.				Deluge Valve
Bar	PSI	Bar		PSI		Size
3	44	8	11	116	160	3 – 4 – 6 – 8"
4	58	9	12	131	174	3 – 4 – 6 – 8"
5	73	10	13	145	189	3 – 4 – 6 – 8"
6	87	11	14	160	203	3 – 4 – 6 – 8"
7	102	12	15	174	218	3 – 4 – 6 – 8"
8	116	13	16	189	232	3 – 4 – 6"
9	131	14	17	203	247	3 – 4 – 6"
10	145	15	18	218	261	3 – 4 – 6"
11	160	16	19	232	276	3 – 4 – 6"
12	174	17	20	247	290	3 – 4 – 6"

GW SPRINKLER A/S

Kastanievej 15, DK-5620 Glamsbjerg, Denmark
Tel.: +45 64 72 20 55 Fax.: +45 64 72 22 55
Email: sales.dep@gwsprinkler.com

Page: 2 of 5

DATA SHEET No: **DV050 1007 C**

Issue / Date: 02.07.2019

GW C300

AUTOMATIC WATER CONTROL VALVE

PRESSURE REDUCING WITH PNEUMATIC ACTUATOR



GW SPRINKLER A/S

Specials: Client specified solutions can be accommodated on request – e.g. special instrumentation, special fittings, surface treatment, pressure setting. Consult GW for options.

Weights: (in kilograms, approximate)

	80mm (3")	100mm (4")	150mm (6")	200mm (8")	250mm (10")	300mm (12")
Ni.Al.Bronze	25	30	49	68	108	185
Super Duplex	26	32	53	73	112	192
Titanium	17	19	31	42	66	111

Maintenance: Every 3 year the valve should be disassembled, inspected and the elastomeric components replaced – i.e. replace the elastomeric sleeve, diaphragms and seals in service and those held unused as spare stock. Spares should be used within a two year shelf life to provide a 3 year “in service” life (5 year total life).
The “in service” life of the elastomeric sleeve can be extended annually to a maximum “in service” period of 5 years from the date of first installation or 6 years from manufacture, whichever is the sooner, provided that a “maximum extension test” (see IOM manual no. 6470645) to fully stretch the flow control sleeve within the deluge valve body, is performed.

Spare

Parts: Refer to data sheet no.: DV070 1001 - GW C-300 General Spares Schedule

Pressure data:

	Min.	Max.	Note
Design pressure		20 bar	
Recommended operating pressure	5 to 8 bar above valve set-pressure		
Regulated pressure (outlet pressure) – std.	3 bar	7 bar	(blue spring) standard
Set-pressure (factory setting) – standard.		4 bar	(or to specification)
Regulated pressure (outlet pressure) – high	7 bar	12 bar	(silver spring) optional
Regulated pressure (outlet pressure) – high	Set-pressure in excess of 12 bar – consult GW.		
Inlet pressure to achieve full open	4 bar		
Pneumatic Actuator Air Supply	1,5 bar	12 bar	
Pneumatic Actuator trip point (switch open)		< 0,5 bar	@ pilot line falling pressure

Materials:

	Valve		
	Ni.Al.Bronze	Super Duplex	Titanium
Wetted parts	Ni.Al.Bronze to UNS C95800, UNS C63000	SuperDuplex Cr.25 to ASTM A890, UNS J92205	Titanium (unalloyed) to ASTM B367, B348 UNS R50400 – Gr.2
Non-wetted parts	Gun Metal to UNS C93200, St.Steel to UNS S31600 /03	Gun Metal (NiSn plated) UNS C93200, St.Steel to UNS S31600 /03	Gun Metal (NiSn plated) UNS C93200, St.Steel to UNS S31600 /03

GW SPRINKLER A/S

Kastanievej 15, DK-5620 Glamsbjerg, Denmark
Tel.: +45 64 72 20 55 Fax.: +45 64 72 22 55
Email: sales.dep@gwsprinkler.com

Page: 3 of 5

DATA SHEET No: **DV050 1007 C**

Issue / Date: 02.07.2019

GW C300
AUTOMATIC WATER CONTROL VALVE
 PRESSURE REDUCING
 WITH PNEUMATIC ACTUATOR



GW SPRINKLER A/S

Pipes	Cupronickel CuNi 9010, UNS C70600	Titanium (unalloyed) to ASTM B338, UNS R50400 – Gr.2	Titanium (unalloyed) to ASTM B338, UNS R50400 – Gr.2
Compress fittings	Ni.Al.Bronze to UNS C63000	SuperDuplex Cr.25 to UNS S32750	Titanium (unalloyed) to ASTM B348 UNS R50400 – Gr.2
Flow Ctrl. Sleeve	Natural Rubber	Natural Rubber	Natural Rubber

Material certification to EN10204 3.1, and PMI-testing on request.

Pressure loss:

	80mm (3")	100mm (4")	150mm (6")	200mm (8")	250mm (10")	300mm (12")
Cv	240	430	880	1790	2060	2990
Kv	206	370	757	1540	1770	2570
Friction loss @ 50% of max. flow (bar)	0,11	0,32	0,11	0,19	-	-

Cv: Flow coefficient (imperial) = flow rate (US gal/min) across valve @ 1 psi head loss.

Kv: Flow factor (metric) = flow rate (m³/hr.) across valve @ 1 bar head loss.

Testing: Every valve is factory tested - i.e. static body & seat pressure test + functional flow test. An individual test report is issued for each valve.

Set-pressure: For pilot operated pressure reducing valves the SET-pressure is the outlet residual pressure for which the pilot regulator of the valve has been adjusted and is expected to maintain, regardless of changing flow rate and varying inlet pressures.

Position Indicator: Per FM Standard 1362, a position indicator must be provided with FM approved pressure reducing valves. This can be accomplished by fitting the valve with upstream and downstream pressure gauges (see below "Options").

Options: Pressure monitoring via Gauge Block fitted to upstream and/or downstream side of centre block. Each Gauge Block provides 3 off 1/4" NPT female ports for connection of pressure gauge, pressure switch etc. All ports can be blocked by a central restrictor, for safe in-service removal of connected instruments.

Service: If required, GW Sprinkler A/S can undertake a full overhaul/refurbishment of your C-300 deluge valve at the factory in Denmark. This will include complete dismantling of the valve, glass blast cleaning of corroded parts, assessment of wear/corrosion, replacement of elastomeric parts, replacement of corroded/damaged parts (in dialogue with customer), static pressure test, functional test, set-pressure adjustment, full test report.

GW SPRINKLER A/S

Kastanievej 15, DK-5620 Glamsbjerg, Denmark
 Tel.: +45 64 72 20 55 Fax.: +45 64 72 22 55
 Email: sales.dep@gwsprinkler.com

GW C300

AUTOMATIC WATER CONTROL VALVE

PRESSURE REDUCING
WITH PNEUMATIC ACTUATOR



GW SPRINKLER A/S

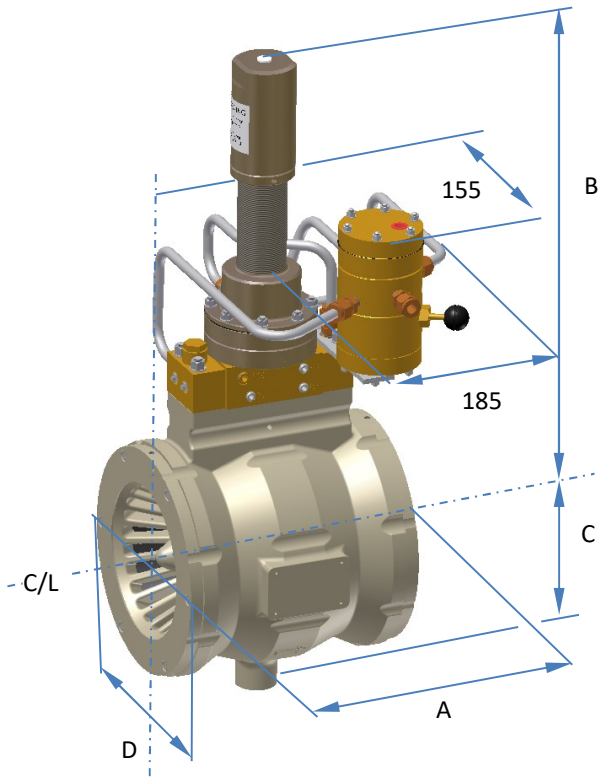

All dimensions in mm.

	A	B *)	C	D **)
80 (3")	167	405	112	128
100 (4")	167	427	132	161
150 (6")	237	459	162	222
200 (8")	304	487	184	295
250 (10")	350	522	217	336
300 (12")	440	560	248	406

*) SET at 4 bar (blue spring)

***) Fitment: Wafer fits between ANSI/ASME B16.5 Class 150 or 300 lbs. flanges using full length studs, nuts and washers. Gasket to ANSI B16.21 RF.

P & ID:

Port	Description	Size
R1	Inlet Restrictor (close)	
R2	Jacket Restrictor	
R3	Outlet Restrictor (open)	
TP1	Exhaust to open valve	1/4" NPT
TP2	Supply to close valve	1/4" NPT
TP3	Inlet to close valve	1/4" NPT
TP4	Plugged	1/4" NPT
TP6	Manual Release Valve	1/2" NPT
CP1	Inlet to open valve	1/4" NPT
CP2	Exhaust to open valve	1/4" NPT
CP3	Outlet to close valve	1/4" NPT
CP4	Inlet to close valve	1/4" NPT
CP5	Plugged	1/4" NPT
Air	Supply in Actuator top	1/4" NPT

R = Restrictor (needle valve)
TP = Terminal Port

IO&M manual: 64 70645

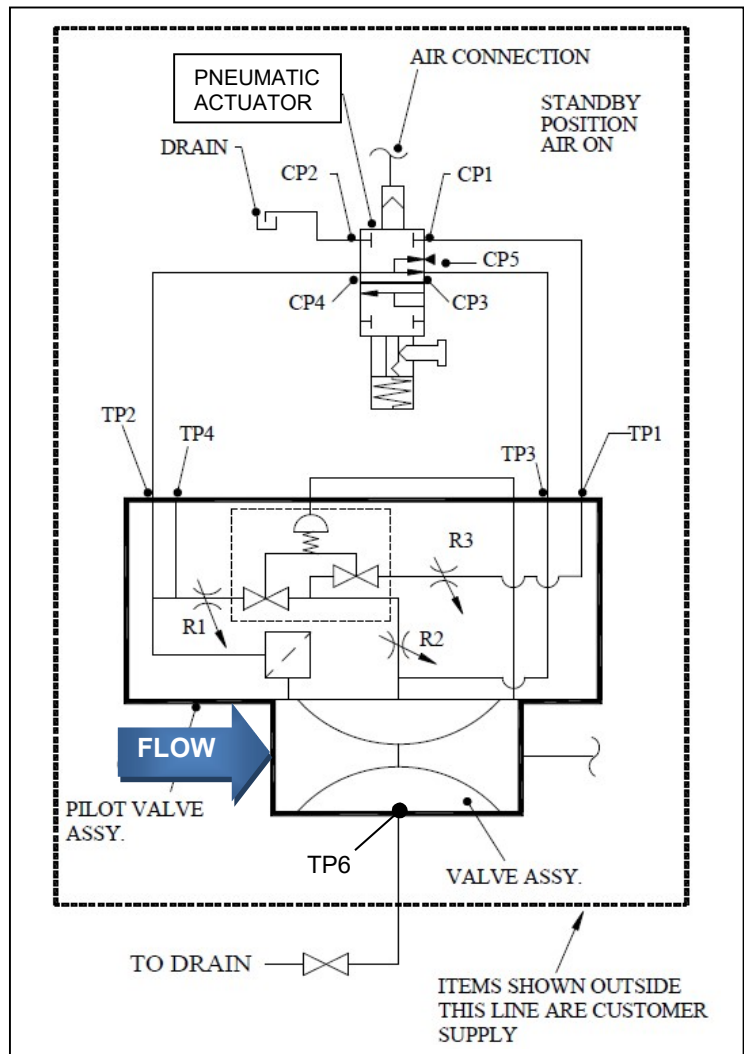

GW SPRINKLER A/S

Kastanievej 15, DK-5620 Glamsbjerg, Denmark
Tel.: +45 64 72 20 55 Fax.: +45 64 72 22 55
Email: sales.dep@gwsprinkler.com