

# GW C300 Automatic Water Control Valve



INTEGRAL LATCHING PNEUMATIC ACTUATOR

GW SPRINKLER A/S



PART NUMBER			
	Ni Al Bronze	Super Duplex	Titanium
3"	CV64.561.14FM	CV64.561.16FM	CV64.561.17FM
4"	CV64.562.14FM	CV64.562.16FM	CV64.562.17FM
6"	CV64.563.14FM	CV64.563.16FM	CV64.563.17FM
8"	CV64.564.14FM	CV64.564.16FM	CV64.564.17FM
10"	CV64.565.14FM	CV64.565.16FM	CV64.565.17FM
12"	CV64.566.14FM	CV64.566.16FM	CV64.566.17FM



**Function:** This is a hydraulically operated elastomeric sleeve valve. It is typically fitted into a fire water main – or section branch pipe, where a controlled opening and closing is required. Installation can be either horizontally or vertically. The GW C-300 deluge valve is “self-powered” – and utilizes the system upstream (inlet) pressure to hydraulically close and open. It is activated pneumatically via the integral actuator, to trip upon pilot line air pressure drop. The linear “straight thru” valve design with the aqua dynamically shaped fingers provides a remarkable low pressure drop across the valve in the fully open position.

**Operation:** This elastomeric sleeve type valve is normally closed, and is maintained in the closed position by diverting upstream water directly to the flow control sleeve cavity. This is accomplished by the integral pneumatic actuator, mounted on the deluge valve, in the pressurized (air on) position. Upon instruction (air off) the actuator switches to open position and water is allowed to drain from within the sleeve cavity, thus releasing the hydraulic pressure that seals the sleeve against the seat. The deluge valve opens in a controlled way as upstream pressure lifts the sleeve off the seat and water starts flowing through the valve gradually expanding the elastomeric flow control sleeve. The opening (and closing) speed is adjustable via restrictors controlling the in and out flow to the sleeve cavity, thus preventing water hammer and damage to downstream pipework and components.

By pilot air pressure drop the actuator is latched in the open-position. The GW C-300 deluge valve will remain open until manually reset. Resetting (closing) is done by first pulling the latch (black knob) and then reinstating air pressure on the actuator. This will switch the actuator to block the drain and allow water to pressurize the sleeve cavity, thus closing the deluge valve.

The GW C-300 deluge valve can be manually activated by opening the **manual release** valve (1/2" Ball Valve) fitted at the bottom of the valve body.

## GW SPRINKLER A/S

Kastanievej 15, DK-5620 Glamsbjerg, Denmark  
Tel.: +45 64 72 20 55 Fax.: +45 64 72 22 55  
Email: sales.dep@gwsprinkler.com

Page: 1 of 5

DATA SHEET No: **DV050 1010 B**

Issue / Date: 02.07.2019

# GW C300 Automatic Water Control Valve



INTEGRAL LATCHING PNEUMATIC ACTUATOR

GW SPRINKLER A/S

- Installation:** Horizontally or vertically.  
Wafer type valve fits between ANSI /ASME B16.5 Class 150 or 300 lbs. flanges, using full length threaded studding, washers and nuts.
- Design:** The GW C-300 deluge valve is developed and designed for maximum reliability when installed and operated in the harshest onshore and offshore environments. To prevent any malfunctioning due to components seizing, sticking or corroding, the number of moving mechanical parts has been reduced to a minimum, and the few moving parts present are ALL 100% isolated (i.e. no water contact) from the flow media. The only moving components in contact with the flow media are the elastomeric parts. A strainer is fitted in the inlet of the valve center block to prevent any debris from entering the hydraulic pilot regulating system.
- Pressure Reduction:** The GW C-300 valve is designed to handle large pressure reductions, and minimize the effects of cavitation and noise. The multi finger construction of the water passageways through the valve, in combination with the conical shaped core, ensures that the pressure is reduced at multiple sites, which avoids large cavitation concentrations and resultant noise and valve damage. The exiting cone in the valve outlet ensures that the cavitation stays longer in the water flow stream thus reducing concentrated damage to valve internals and pipework walls.
- Material:** All materials used in the valve have been rigorously selected to ensure durability when installed and operated in the heavy duty applications the valve is designed for. All wetted parts are as standard in the material Nickel Aluminium Bronze and piping in CuNi 90/10.

**Finish:** Natural (metallic, non-painted surface).

**Approval:**



The GW C-300 Non Regulating deluge valve is FM Approved to FM Class 1020: "Approval Standard for Automatic Water Control Valves" in the sizes: 3"- 4"- 6"- 8" - 10" - 12".

For specific valve approval details consult FM Approval Guide @: [www.approvalguide.com](http://www.approvalguide.com), or ask GW Sprinkler A/S

**Specials:** Client specified solutions can be accommodated on request – e.g. special instrumentation, special fittings, surface treatment. Consult GW for options.

**Weight:** (in kilograms, approximate)

	80mm (3")	100mm (4")	150mm (6")	200mm (8")	250mm (10")	300mm (12")
Ni.Al.Bronze	11	16	35	54	94	171
Super Duplex	12	17	36	56	97	176
Titanium	7	10	20	31	55	100

## GW SPRINKLER A/S

Kastanievej 15, DK-5620 Glamsbjerg, Denmark  
Tel.: +45 64 72 20 55 Fax.: +45 64 72 22 55  
Email: sales.dep@gwsprinkler.com

Page: 2 of 5

DATA SHEET No: **DV050 1010 B**

Issue / Date: 02.07.2019

# GW C300 Automatic Water Control Valve



INTEGRAL LATCHING PNEUMATIC ACTUATOR

GW SPRINKLER A/S

**Maintenance:** Every 3 year the valve should be disassembled, inspected and the elastomeric components replaced – i.e. replace the elastomeric sleeve, diaphragms and seals in service and those held unused as spare stock. Spares should be used within a two-year shelf life to provide a 3 year “in service” life (5-year total life).  
The “in service” life of the elastomeric sleeve can be extended annually to a maximum “in service” period of 5 years from the date of first installation or 6 years from manufacture, whichever is the sooner, provided that a “maximum extension test” (see IOM manual no. 6470442) to fully stretch the flow control sleeve within the deluge valve body, is performed.

**Spare Parts:** Refer to data sheet no.: DV070 1001 - GW C-300 General Spares Schedule

**Pressure data:**

	Min.	Max.	Note
Design pressure		20 bar	
Recommended operating pressure	5 bar	20 bar	
Inlet pressure to achieve full open	4 bar		
Pneumatic Actuator Air Supply	1,5 bar	12 bar	
Pneumatic Actuator trip point (switch open)		< 0,5 bar	@ pilot line falling pressure

**Materials:**

	Valve		
	Ni.Al.Bronze	Super Duplex	Titanium
Wetted parts	Ni.Al.Bronze to UNS C95800, UNS C63000	Super Duplex Cr.25 to ASTM A890, UNS J92205	Titanium (unalloyed) to ASTM B367, B348 UNS R50400 – Gr.2
Non-wetted parts	Gun Metal to UNS C93200, St.Steel to UNS S31600 /03	Gun Metal (NiSn plated) UNS C93200, St.Steel to UNS S31600 /03	Gun Metal (NiSn plated) UNS C93200, St.Steel to UNS S31600 /03
Pipes	Cupronickel CuNi 9010, UNS C70600	TBA	Titanium (unalloyed) to ASTM B338, UNS R50400 – Gr.2
Compress fittings	Ni.Al.Bronze to UNS C63000	Super Duplex Cr.25 to UNS S32750	Titanium (unalloyed) to ASTM B348 UNS R50400 – Gr.2
Flow Ctrl. Sleeve	Natural Rubber	Natural Rubber	Natural Rubber

Material certification to EN10204 3.1, and PMI-testing on request.

**GW SPRINKLER A/S**

Kastanievej 15, DK-5620 Glamsbjerg, Denmark  
Tel.: +45 64 72 20 55 Fax.: +45 64 72 22 55  
Email: sales.dep@gwsprinkler.com

Page: 3 of 5

DATA SHEET No: **DV050 1010 B**

Issue / Date: 02.07.2019

# GW C300 Automatic Water Control Valve



INTEGRAL LATCHING PNEUMATIC ACTUATOR

GW SPRINKLER A/S

## Pressure loss:

	80mm (3")	100mm (4")	150mm (6")	200mm (8")	250mm (10")	300mm (12")
Cv	240	430	880	1790	2060	2990
Kv	206	370	757	1540	1770	2570

Cv: Flow coefficient (imperial) = flow rate (US gal/min) across valve @ 1 psi head loss.

Kv: Flow factor (metric) = flow rate (m<sup>3</sup>/hr.) across valve @ 1 bar head loss.

**Testing:** Every valve is factory tested - i.e. static body & seat pressure test + functional flow test. An individual test report is issued for each valve.

**Options:** Pressure monitoring via Gauge Block fitted to upstream and/or downstream side of center block. Each Gauge Block provides 3 off 1/4" NPT female ports for connection of pressure gauge, pressure switch etc. All ports can be blocked by a central restrictor, for safe in-service removal of connected instruments.

**Service:** If required, GW Sprinkler A/S can undertake a full overhaul/refurbishment of your C-300 deluge valve at the factory in Denmark. This will include complete dismantling of the valve, glass blast cleaning of corroded parts, assessment of wear/corrosion, replacement of elastomeric parts, replacement of corroded/damaged parts (in dialogue with customer), static pressure test, functional test, set-pressure adjustment, full test report.

---

## GW SPRINKLER A/S

Kastanievej 15, DK-5620 Glamsbjerg, Denmark  
Tel.: +45 64 72 20 55 Fax.: +45 64 72 22 55  
Email: sales.dep@gwsprinkler.com

Page: 4 of 5

DATA SHEET No: **DV050 1010 B**

Issue / Date: 02.07.2019

# GW C300 Automatic Water Control Valve



INTEGRAL LATCHING PNEUMATIC ACTUATOR

GW SPRINKLER A/S

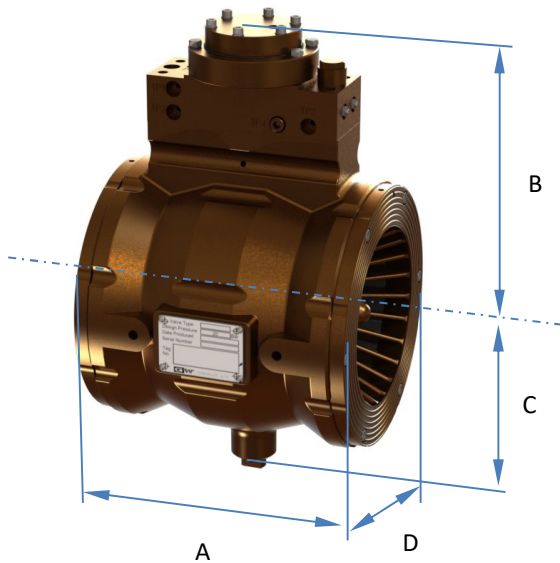

All dimensions in mm.

Valve Size	A	B	C *)	D **)
80 (3")	167	145	95	128
100 (4")	167	167	115	161
150 (6")	237	199	145	222
200 (8")	304	227	167	295
250 (10")	350	263	200	336
300 (12")	440	301	235	406

\*) valve center to 1/2" boss end (unplugged).

\*\*\*) Fitment: Wafer fits between ANSI/ASME B16.5 Class 150 or 300 lbs. flanges using full length studs, nuts and washers. Gasket to ANSI B16.21 RF.

## P & ID:

Port	Description	Size
R1	Inlet Restrictor (close)	
R2	Sleeve Restrictor	
R3	Outlet Restrictor (open)	
TP1	Exhaust to open valve	1/4" NPT
TP2	Plugged	1/4" NPT
TP3	Plugged	1/4" NPT
TP4	Plugged	1/4" NPT
TP5	Plugged	1/4" NPT
TP6	Plugged	1/4" NPT
TP7	Air Supply (Actuator)	1/4" NPT
TP8	Plugged	1/2" NPT

R = Restrictor (needle valve)  
TP = Terminal Port

IO&M manual: 64 70635

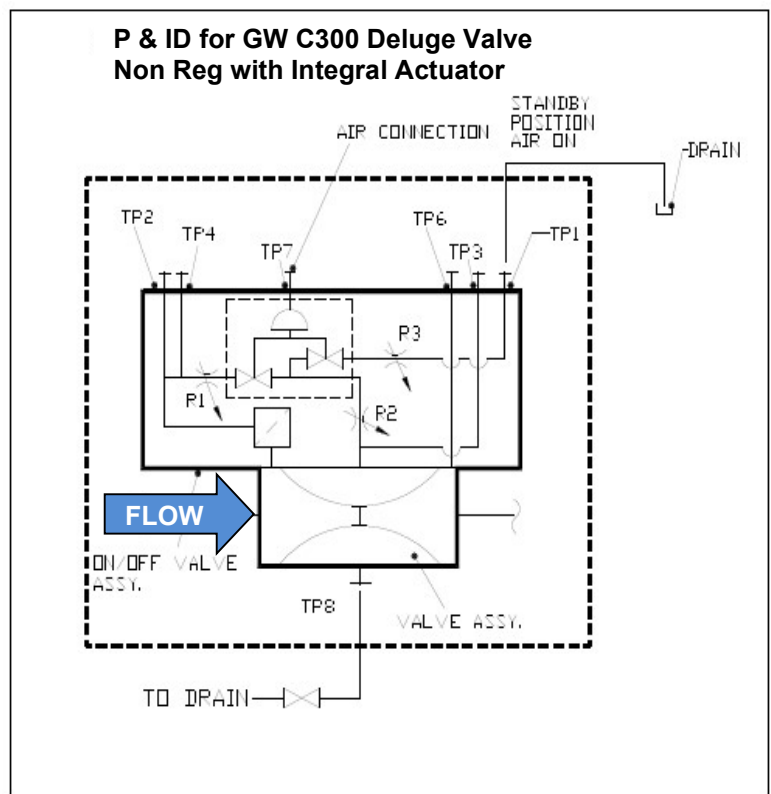

## GW SPRINKLER A/S

Kastanievej 15, DK-5620 Glamsbjerg, Denmark  
Tel.: +45 64 72 20 55 Fax.: +45 64 72 22 55  
Email: sales.dep@gwsprinkler.com

Page: 5 of 5

DATA SHEET No: **DV050 1010 B**

Issue / Date: 02.07.2019