

GW C300 AUTOMATIC WATER CONTROL VALVE

NON REGULATING (w. strainer & restrictors)
WITH SOLENOID (electrical actuation)

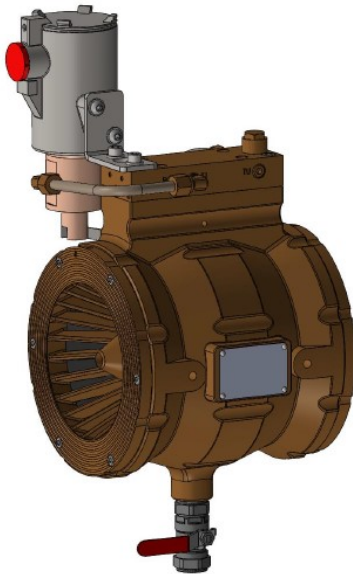

GW SPRINKLER A/S



PART NUMBER			
	Ni Al Bronze	Super Duplex	Titanium
3"	CV64.591.24FM	CV64.591.26FM	CV64.591.27FM
4"	CV64.592.24FM	CV64.592.26FM	CV64.592.27FM
6"	CV64.593.24FM	CV64.593.26FM	CV64.593.27FM
8"	CV64.594.24FM	CV64.594.26FM	CV64.594.27FM
10"	CV64.595.24FM	CV64.595.26FM	CV64.595.27FM
12"	CV64.596.24FM	CV64.596.26FM	CV64.596.27FM



Function: This is a hydraulically operated elastomeric sleeve valve. It is typically fitted into a fire water main – or section branch pipe, where a controlled opening and closing is required. Installation can be either horizontally or vertically. The GW C-300 deluge valve is “self-powered” – and utilizes the system upstream (inlet) pressure to hydraulically close and open. It is activated electrically via the solenoid, to trip upon signal from the detection system /panel or manually activated switch. The linear “straight thru” valve design with the aqua dynamically shaped fingers provides a remarkable low pressure drop across the valve in the fully open position.

Operation: The GW C-300 deluge valve is normally closed, and is maintained in the closed position by diverting upstream water directly to the flow control sleeve cavity. This is accomplished by the 3/2 way solenoid, mounted on the deluge valve, in the de-energized (NC) state. Upon instruction (energizing), the solenoid switches to open position and water is allowed to drain from within the sleeve cavity, thus releasing the hydraulic pressure that seals the sleeve against the seat. The deluge valve opens in a controlled way as upstream pressure lifts the sleeve off the seat, and water starts flowing through the valve, gradually expanding the elastomeric flow control sleeve. The opening (and closing) speed is adjustable via restrictors controlling the in and out flow to the sleeve cavity, thus providing a balanced valve performance, preventing water hammer and damage to downstream pipework and components.

The solenoid is latched in the open position, hence the GW C-300 deluge valve will remain open until manually re-set. Resetting is done by de-energizing the solenoid, followed by pushing the latch from axial to perpendicular position. This will switch the solenoid to closed position, to block the drain and allow water to pressurize the sleeve cavity, thus contracting the elastomeric sleeve against the core seat in the center of the valve casing – closing the deluge valve.

The GW C-300 deluge valve can be manually activated by opening the **manual release** valve (1/2" Ball Valve) fitted at the bottom of the valve body.

GW SPRINKLER A/S

Kastanievej 15, DK-5620 Glamsbjerg, Denmark
Tel.: +45 64 72 20 55 Fax.: +45 64 72 22 55
Email: sales.dep@gwsprinkler.com

Page: 1 of 6

DATA SHEET No: **DV050 1009 C**

Issue / Date: 02.07.2019

GW C300 AUTOMATIC WATER CONTROL VALVE

NON REGULATING (w. strainer & restrictors)
WITH SOLENOID (electrical actuation)



GW SPRINKLER A/S

- Installation:** Horizontally or vertically.
Wafer type valve fits between ANSI /ASME B16.5 Class 150 or 300 lbs. flanges, using full length threaded studding, washers and nuts.
- Design:** The GW C-300 deluge valve is developed and designed for maximum reliability when installed and operated in the harshest onshore and offshore environments. To prevent any malfunctioning due to components seizing, sticking or corroding, the number of moving mechanical parts has been reduced to a minimum, and the few moving parts present are ALL 100% isolated (i.e. no water contact) from the flow media. The only moving components in contact with the flow media are the elastomeric parts. A strainer is fitted in the inlet of the valve center block to prevent any debris from entering the hydraulic regulating system.
- Pressure Reduction:** The GW C-300 valve is designed to handle large pressure reductions, and minimize the effects of cavitation and noise. The multi finger construction of the water passageways through the valve, in combination with the conical shaped core, ensures that the pressure is reduced at multiple sites, which avoids large cavitation concentrations and resultant noise and valve damage. The exiting cone in the valve outlet ensures that the cavitation stays longer in the water flow stream thus reducing concentrated damage to valve internals and pipework walls.
- Material:** All materials used in the valve have been rigorously selected to ensure durability when installed and operated in the heavy duty applications the valve is designed for. All wetted parts are as standard in the material Nickel Aluminum Bronze and piping in CuNi 90/10.
- Finish:** Natural (metallic, non-painted surface).

Approval:



The GW C-300 Non Regulating deluge valve is FM Approved to FM Class 1020: "Approval Standard for Automatic Water Control Valves" in the sizes: 3"- 4"- 6"- 8" - 10" - 12".

For specific valve approval details consult FM Approval Guide @: www.approvalguide.com, or ask GW Sprinkler A/S

Specials: Client specified solutions can be accommodated on request – e.g. special instrumentation, special fittings, surface treatment. Consult GW for options.

Weights: (in kilograms, approximate)

	80mm (3")	100mm (4")	150mm (6")	200mm (8")	250mm (10")	300mm (12")
Ni.Al.Bronze	11	16	35	54	94	171
Super Duplex	12	17	36	56	97	176
Titanium	7	10	20	31	55	100

GW SPRINKLER A/S

Kastanievej 15, DK-5620 Glamsbjerg, Denmark
Tel.: +45 64 72 20 55 Fax.: +45 64 72 22 55
Email: sales.dep@gwsprinkler.com

Page: 2 of 6

DATA SHEET No: **DV050 1009 C**

Issue / Date: 02.07.2019

GW C300 AUTOMATIC WATER CONTROL VALVE

NON REGULATING (w. strainer & restrictors)
WITH SOLENOID (electrical actuation)



GW SPRINKLER A/S

Maintenance: Every 3 year the valve should be disassembled, inspected and the elastomeric components replaced – i.e. replace the elastomeric sleeve, diaphragms and seals in service and those held unused as spare stock. Spares should be used within a two year shelf life to provide a 3 year “in service” life (5 year total life).
The “in service” life of the elastomeric sleeve can be extended annually to a maximum “in service” period of 5 years from the date of first installation or 6 years from manufacture, whichever is the sooner, provided that a “maximum extension test” (see IOM manual no. 6470442) to fully stretch the flow control sleeve within the deluge valve body, is performed.

Spare Parts: Refer to data sheet no.: DV070 1001 - GW C-300 General Spares Schedule

Pressure data:

	Min.	Max.	Note
Design pressure		20 bar	
Recommended operating pressure	5 bar	20 bar	
Inlet pressure to achieve full open	4 bar		

Materials:

	Valve		
	Ni.Al.Bronze	Super Duplex	Titanium
Wetted parts	Ni. Al. Bronze to UNS C95800, UNS C63000	SuperDuplex Cr.25 to ASTM A890, UNS J92205	Titanium (unalloyed) to ASTM B367, B348 UNS R50400 – Gr.2
Non-wetted parts	Gun Metal to UNS C93200, St. Steel to UNS S31600 /03	Gun Metal (NiSn plated) UNS C93200, St. Steel to UNS S31600 /03	Gun Metal (NiSn plated) UNS C93200, St. Steel to UNS S31600 /03
Pipes	Cupronickel CuNi 9010, UNS C70600	TBA	Titanium (unalloyed) to ASTM B338, UNS R50400 – Gr.2
Compress fittings	Ni. Al. Bronze to UNS C63000	SuperDuplex Cr.25 to UNS S32750	Titanium (unalloyed) to ASTM B348 UNS R50400 – Gr.2
Flow Ctrl. Sleeve	Natural Rubber	Natural Rubber	Natural Rubber

Material certification to EN10204 3.1, and PMI-testing on request.

GW SPRINKLER A/S

Kastanievej 15, DK-5620 Glamsbjerg, Denmark
Tel.: +45 64 72 20 55 Fax.: +45 64 72 22 55
Email: sales.dep@gwsprinkler.com

Page: 3 of 6

DATA SHEET No: **DV050 1009 C**

Issue / Date: 02.07.2019

GW C300 AUTOMATIC WATER CONTROL VALVE

NON REGULATING (w. strainer & restrictors)
WITH SOLENOID (electrical actuation)



GW SPRINKLER A/S

Pressure loss:

	80mm (3")	100mm (4")	150mm (6")	200mm (8")	250mm (10")	300mm (12")
Cv	240	430	880	1790	2060	2990
Kv	206	370	757	1540	1770	2570

Cv: Flow coefficient (imperial) = flow rate (US gal/min) across valve @ 1 psi head loss.

Kv: Flow factor (metric) = flow rate (m³/hr.) across valve @ 1 bar head loss.

Testing: Every valve is factory tested - i.e. static body & seat pressure test + functional flow test. An individual test report is issued for each valve.

Options: Pressure monitoring via Gauge Block fitted to upstream and/or downstream side of center block. Each Gauge Block provides 3 off 1/4" NPT female ports for connection of pressure gauge, pressure switch etc. All ports can be blocked by a central restrictor, for safe in-service removal of connected instruments.

Service: If required, GW Sprinkler A/S can undertake a full overhaul/refurbishment of your C-300 deluge valve at the factory in Denmark. This will include complete dismantling of the valve, glass blast cleaning of corroded parts, assessment of wear/corrosion, replacement of elastomeric parts, replacement of corroded/damaged parts (in dialogue with customer), static pressure test, functional test, set-pressure adjustment, full test report.

GW SPRINKLER A/S

Kastanievej 15, DK-5620 Glamsbjerg, Denmark
Tel.: +45 64 72 20 55 Fax.: +45 64 72 22 55
Email: sales.dep@gwsprinkler.com

Page: 4 of 6

DATA SHEET No: **DV050 1009 C**

Issue / Date: 02.07.2019

GW C300 AUTOMATIC WATER CONTROL VALVE

NON REGULATING (w. strainer & restrictors)
WITH SOLENOID (electrical actuation)



GW SPRINKLER A/S

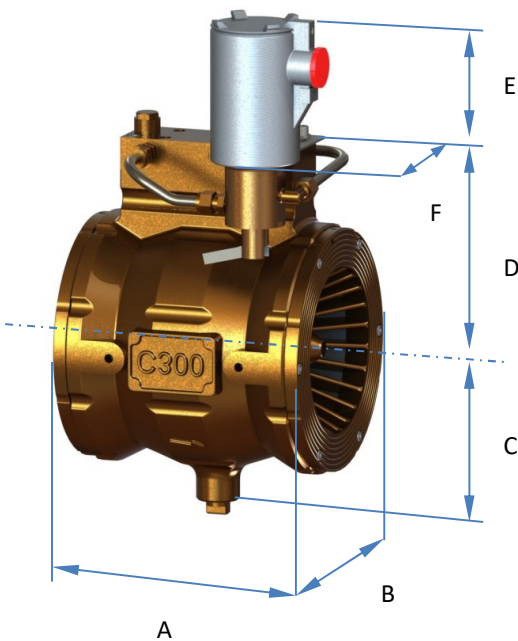

All dimensions in mm.

Valve Size	A	B **)	C *)	D	E	F
80 (3")	167	128	95	145	150	150
100 (4")	167	161	115	167	150	150
150 (6")	237	222	145	198	150	150
200 (8")	304	295	167	227	150	150
250 (10")	350	336	200	262	150	150
300 (12")	440	406	235	300	150	150
*)	valve center to 1/2" boss end (unplugged).					
**)	Fitment: Wafer fits between ANSI/ASME B16.5 Class 150 or 300 lbs. flanges using full length studs, nuts and washers. Gasket to ANSI B16.21 RF.					

P & ID:

Port	Description	Size
RI	Inlet Restrictor (close)	
RO	Outlet Restrictor	
TU	Supply from upstream	1/4" NPT
TI	Inlet sleeve cavity	1/4" NPT
TO	Plugged	1/4" NPT
TD	Plugged (downstream)	1/4" NPT
TP	Plugged (manual release)	1/2" NPT
A	Solenoid INLET	1/4" NPT
B	Solenoid OUTLET	1/4" NPT
C	Solenoid EXHAUST	1/4" NPT

R = Restrictor (needle valve)
TP = Terminal Port

IOM-manual : 64 70635

P & ID for GW C300 Deluge Valve Non Reg. with Solenoid

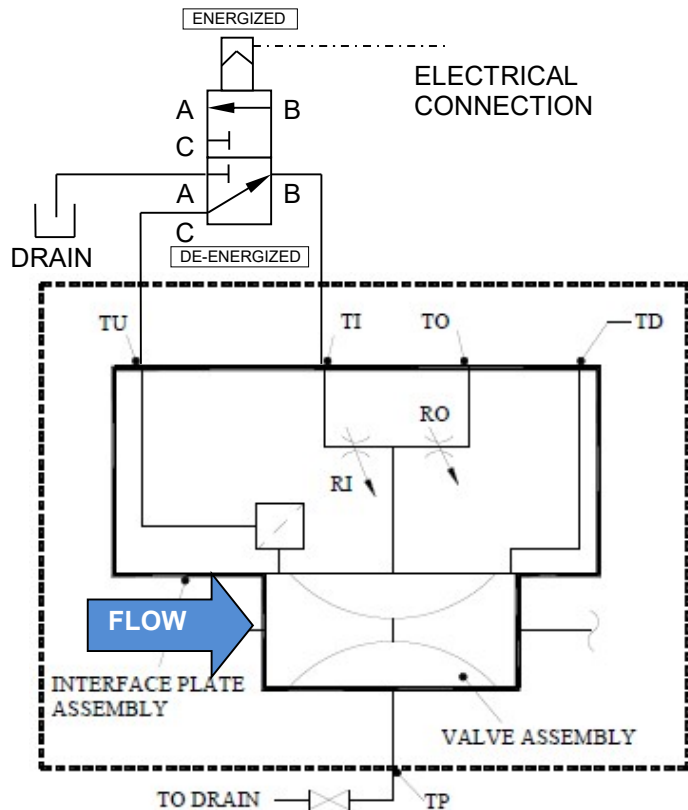

GW SPRINKLER A/S

Kastanievej 15, DK-5620 Glamsbjerg, Denmark
Tel.: +45 64 72 20 55 Fax.: +45 64 72 22 55
Email: sales.dep@gwsprinkler.com

Page: 5 of 6

DATA SHEET No: **DV050 1009 C**

Issue / Date: 02.07.2019

GW C300 AUTOMATIC WATER CONTROL VALVE

NON REGULATING (w. strainer & restrictors)
WITH SOLENOID (electrical actuation)



GW SPRINKLER A/S

Solenoid Data:

Type	ICO4S 1/4" 3/2 A-L-L
Materials of construction	
Pot & Cover	SS316
Valve body	Ni Al Bronze (sea water application)
O-rings	High Nitrile (NBR)
Coil insulation	Class H
Max. inlet pressure	20 bar
Flow Rates	Cv = 0,8 / Kv = 11,5
Temperature ratings	
media	Min/Max -20°/90°C
ambient	Min/Max 0°/60°C
Conduit Connection	M20 x 1,5 Conduit Thread
Power Consumption	9,6 W (for extreme service)
Voltage	24 DC
IP	IP66/X8 NEMA 4X
Configuration	NC (standard) / (NO (optional))
ATEX	Complies with ATEX Directive 94/9/EC
ATEX Code	Ex II 2 G Exd II C T6/T4

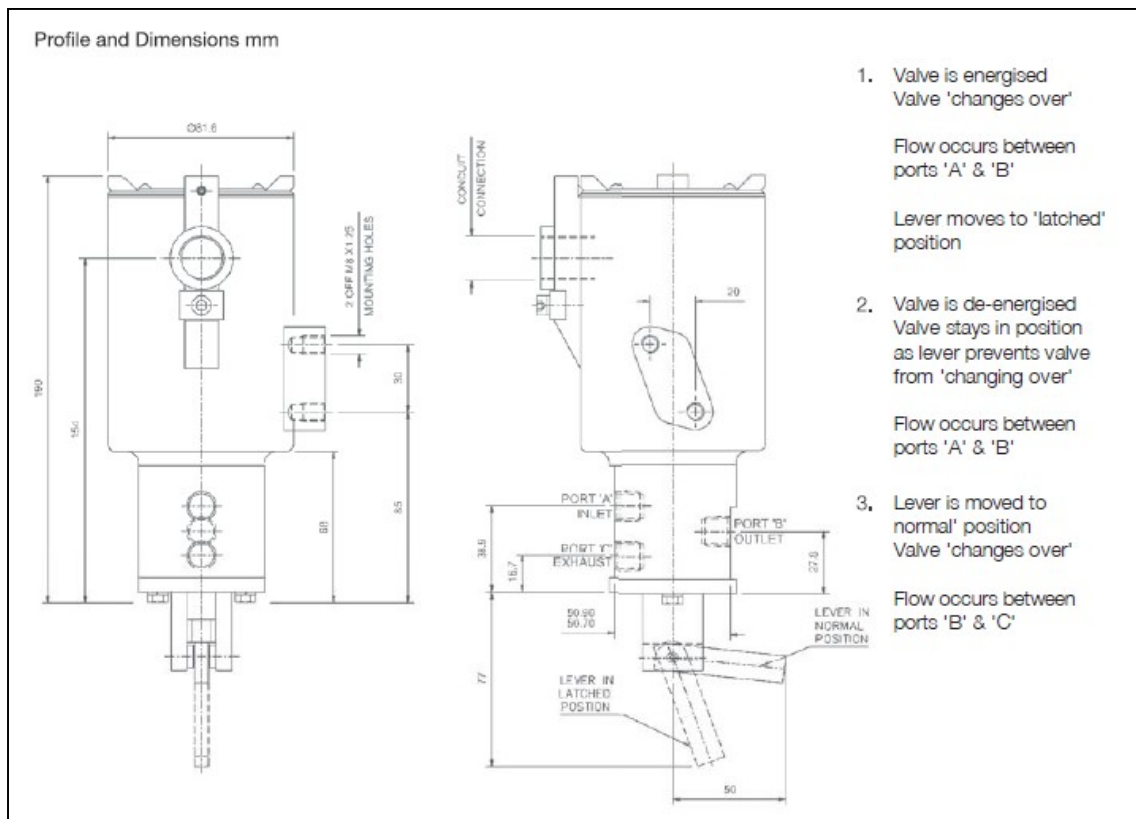

GW SPRINKLER A/S

Kastanievej 15, DK-5620 Glamsbjerg, Denmark
Tel.: +45 64 72 20 55 Fax.: +45 64 72 22 55
Email: sales.dep@gwsprinkler.com