

GW-S

Detector Head

10mm, K-57, Standard Response



GW SPRINKLER A/S

DESCRIPTION

The GW-S sprinkler series offers high quality, European manufactured, modern compact design, that meet the rigid test requirements set out by the world leading approval authorities. The unique GW PTFE / double groove seal in combination with high end heat responsive frangible glass bulbs guarantee durable operation and reliable performance. The use of precisely CNC-machined hot forged frames eliminates the risk of porosity. All manufacturing and testing processes are performed strictly in compliance with our quality management system, certified to ISO 9001.

APPLICATION

GW-S standard response detectors are used in fixed fire protection systems. The detector head is typically fitted in the pilot line of a deluge detection system. When exposed to heat from a fire the detector heat-sensitive glass bulb shatters and the detector head goes open. This in turn will release the air from the pilot line causing a pressure drop which will trip the deluge valve to discharge water through all open spray nozzles and control / extinguish the fire.

TECHNICAL SPECIFICATION

STYLE	Detector
RTI-VALUE	RTI > 100, Standard Response A
GLASS BULB DIAMETER	Ø 5 mm
TEMPERATURE RATING	57, 68, 79, 93, 141, 182, 260°C
ORIFICE:	Ø 9,5 mm
K-FACTOR:	57 lpm / bar ^{1/2}
NOMINAL THREAD:	10 mm (3/8" BSPT), length: 12mm
MAX. WORKING PRESSURE	12 bar
SYSTEM TEST PRESSURE	20 bar
FACTORY TEST PRESSURE	35 bar
WEIGHT	60 grams
OVERALL LENGTH	53 mm
FINISHES	Natural (Brass), chrome plated, polyester powder coated (RAL)

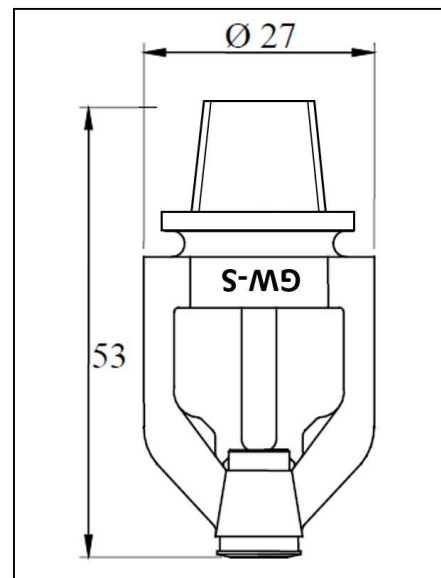

OPTIONS

For improved corrosion resistance the GW-S series may be supplied (on request) in superior materials, such as: stainless steel SS316 or 254SMO, Nickel Aluminium Bronze and even in Titanium. Also available with ENP plating (electroless nickel plating).

Consult GW Sprinkler for available options.

INSTALLATION

Install GW-S Detector in pendent or upright position in accordance with the latest published installation standards i.e. EN12845, CEA4001, NFPA13 or NFPA 15.

Detector heads incorporate highly sensitive and fragile glass bulbs and the utmost care must be taken during handling and installation not to damage the glass bulb in any way! Never install detectors that have been dropped, damaged or fully or partly lacks glass bulb fluid. Install only detectors in pipework that is in its final place to prevent mechanical damage of the detector.

Use only GW sprinkler wrench or box-spanner. Recommended torque to obtain leak tight joint: 10 – 20 Nm.

GW-S Detector Head 10mm, K-57, Standard Response



GW SPRINKLER A/S

Detectors made from brass material should only be installed in non-corrosive environments and environments free of ammonia, chloride vapors and cleaning solutions.

MAINTENANCE

The deluge/detection system should be inspected and maintained according to e.g. NFPA 25.

Detector heads should be inspected on an annual basis. Ensure the detector heads are not used for hanging any objects, and do not show signs of leakage or corrosion. Detectors found to be painted, coated or otherwise altered after leaving the factory must be replaced. Also replace any detector that has a cracked bulb or has lost liquid from its bulb.

Dusty detectors can be gently cleaned using a feather duster – or similar gentle method/tool.

Detector heads are recommended to be inspected, tested and maintained by a qualified Inspection Service in accordance with local requirements and/or national codes.

GW-S detector heads are supplied in special purpose built styro-foam boxes for maximum protection. Spare detector heads should always be stored / kept in the original packaging until installation.

WATER FLOW GRAPH

