

GW DELUGE VALVE STATION

MK III CAST IRON – HYDRAULIC (ELECTRIC)

GENERAL DECSCRIPTION

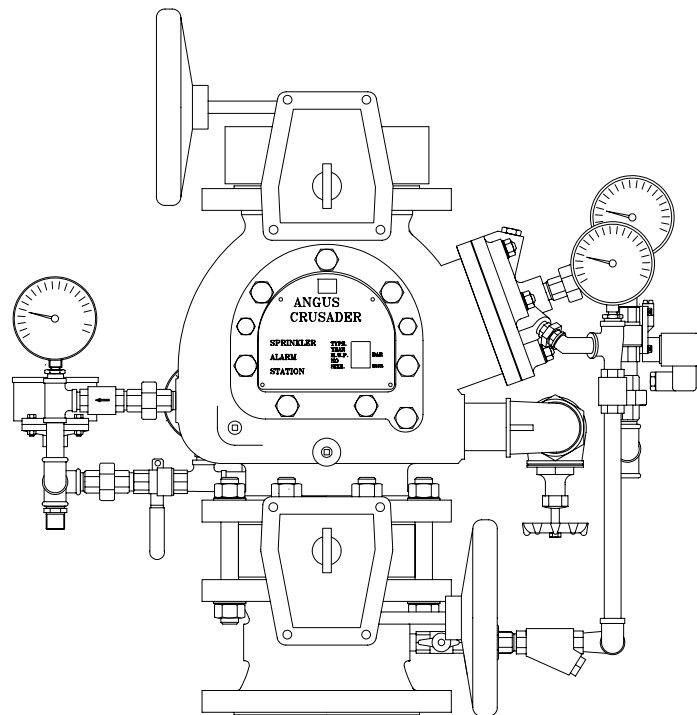

General Description

The GW Mark III Deluge Valve Station comprises a Mk III Deluge Valve (LPC approved) sandwiched between butterfly isolation valves (to LPC rules), a spool piece normally flanged PN16 and all necessary trim, common key padlocks, pressure gauges and pressure switches to enable the valve to operate.

All stations are arranged for bottom entry, top exit, flanged PN16 and rated for supply pressures up to 16 bar.

Stations are supplied in three sizes, 100, 150 and 200mm nominal bore, and are supplied pressure tested with all trim fully assembled, crated for shipment.

Optional extras:

Water motor alarm gong

Glycerine filled pressure gauges

Single or double solenoid valves for releasing latching water pressure (Electro/Hydraulic operation)

Monitored (with microswitch) butterfly valves

Explosion proof pressure switches and solenoid valves

For valve options such as Aluminium Bronze body or ANSI flanges refer to the GW Mk III Deluge Valve data sheet.

The right is reserved to vary or modify any specifications without prior notice

GW SPRINKLER A/S

Kastanievej 15, DK 5620-Glamsbjerg, Denmark

TEL: +45 64722055 FAX: +45 64722255

Email: sales.dep@gwspinkler.com

Data sheet also available at www.gwspinkler.com

DATA SHEET No: **GW DV020 1001 A**

Data Sheet: Deluge Valve MK3 Hyd
General Description

Page: Page 1 of 3
Date: 15th June 2007

GW DELUGE VALVE STATION

MK III CAST IRON – HYDRAULIC (ELECTRIC)

GENERAL DESCRIPTION

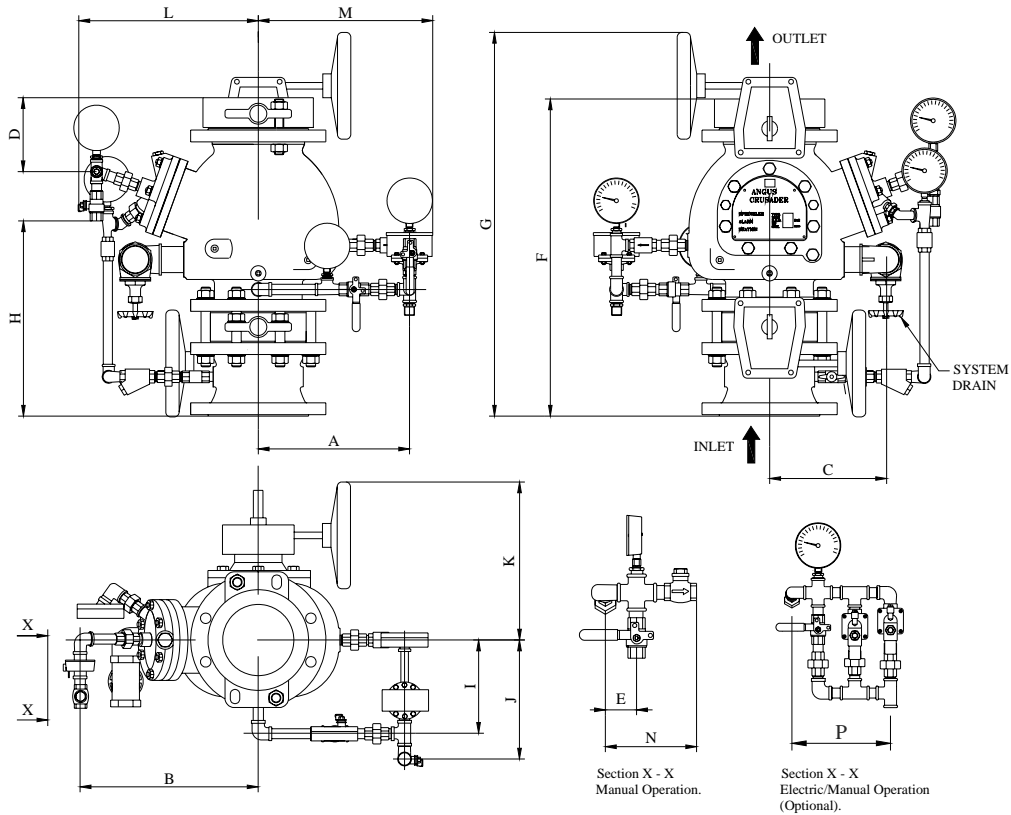

Size mm	A	B	C	D	E	F	G	H	I	J	K	L	M	N	P	Weight
100	325	345	270	100	55	600	710	390	145	200	240	390	370	150	190	133 kg
150	325	370	320	150	55	660	820	400	185	240	320	415	370	150	190	167 kg
200	375	390	365	230	55	750	910	410	215	270	349	435	420	150	190	250 kg

Standard trim:

Butterfly isolation valves top and bottom (lower valve located with a spool piece).

Water priming line to feed the hydraulic diaphragm complete with strainer, lockable isolation valve, pressure gauge and non-return valve.

Bell line with lockable isolation valve, bell test line complete with lockable ball valve, drip union, pressure gauge, pressure switch factory set to operate at 1 bar rising and a non return valve to stop water entering the valve body during the bell test.

Drain valve, 2" globe.

Hydraulic line with pressure gauge, manual release via a lockable ball valve and facility for detector line connection.

The right is reserved to vary or modify any specifications without prior notice

GW SPRINKLER A/S

Kastanievej 15, DK 5620-Glamsbjerg, Denmark

TEL: +45 64722055 FAX: +45 64722255

Email: sales.dep@gwspinkler.com

Data sheet also available at www.gwspinkler.com

DATA SHEET No: **GW DV020 1001 A**

Data Sheet: Deluge Valve MK3 Hyd
General Description

Page: Page 2 of 3
Date: 15th June 2007

GW DELUGE VALVE STATION MK III CAST IRON – HYDRAULIC (ELECTRIC) GENERAL DESCRIPTION



ITEM	DESCRIPTION	ITEM	DESCRIPTION
1	PRESSURE GAUGE – TRIP LINE WITH NO LOSS	13	DRAIN – 3mm ORICIFE
2	SOLENOID VALVE (OPTIONAL)	14	BALL VALVE – ISOLATE BELL
3	SOLENOID VALVE (OPTIONAL)	15	WATER TURBINE AND GONG (NOT STANDARD SUPPLY)
4	BALL VALVE - MANUAL RELEASE	16	HYDRAULIC DIAPHRAGM CHAMBER BLEED SCREW
5	PRESSURE GAUGE – WITH NO LOSS COUPLING –	17	HYDRAULIC DIAPHRAGM
6	NON-RETURN VALVE	18	RESTRICTED ORIFICE
7	FILTER	19	2" DRAIN
8	BALL VALVE – ISOLATE HYDRAULIC DIAPHRAGM	20	MAIN BUTTERFLY ISOLATION VALVE – SUPPLY
9	PRESSURE GAUGE – WITH NO LOSS COUPLING –	21	UPPER BUTTERFLY ISOLATION VALVE – SYSTEM
10	PRESSURE SWITCH – SYSTEM OPERATED	22	LEVER / LATCH
11	BALL VALVE – BELL TEST	23	RUBBER CLACK SEAL
12	NON-RETURN VALVE	24	RUBBER SEAT INSERT (200mm ONLY)

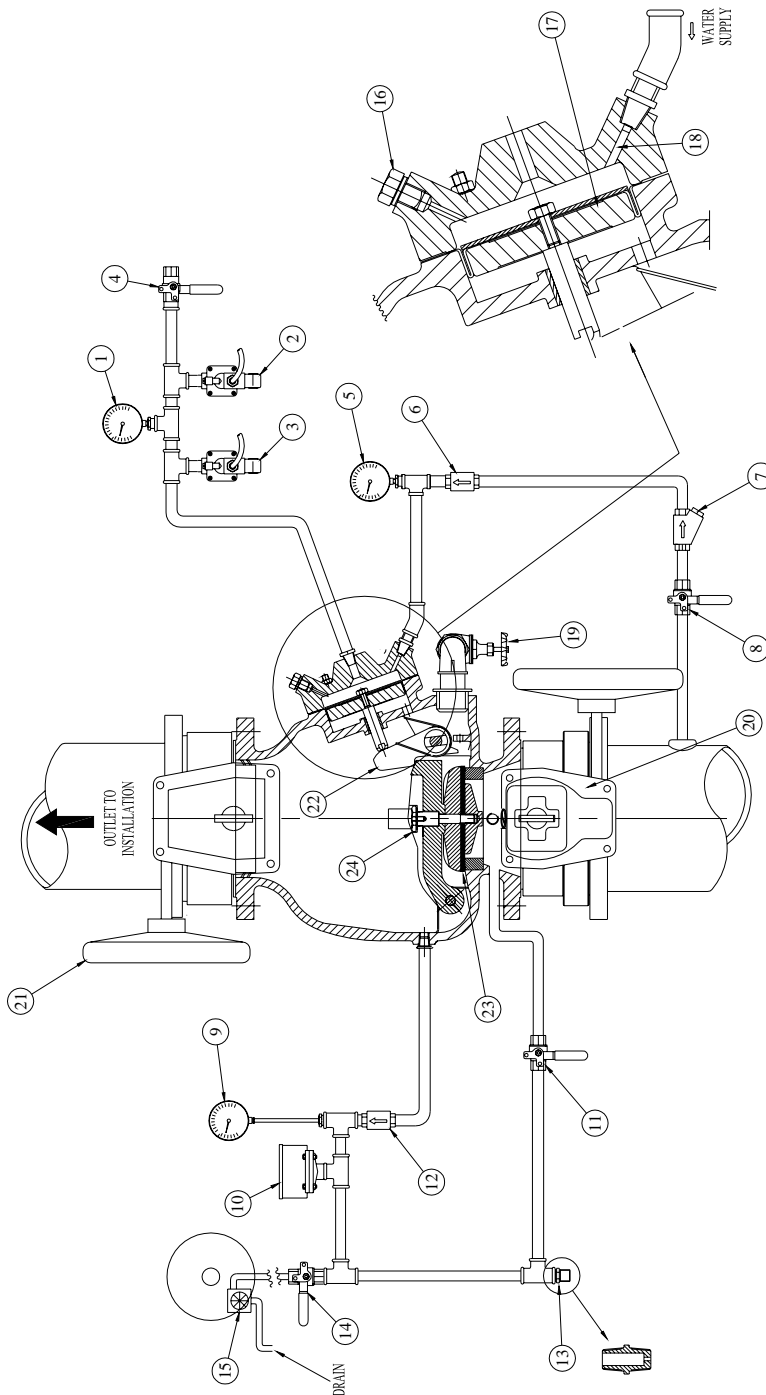

The right is reserved to vary or modify any specifications without prior notice

GW SPRINKLER A/S

Kastanievej 15, DK 5620-Glamsbjerg, Denmark

TEL: +45 64722055 FAX: +45 64722255

Email: sales.dep@gwsprinkler.com

Data sheet also available at www.gwsprinkler.com

DATA SHEET No: GW DV020 1001 A

Data Sheet: Deluge Valve MK3 Hyd
General Description

Page: Page 3 of 3
Date: 15th June 2007